

wallare park wallare park sk

Integration manual – English
Rev. 1.1

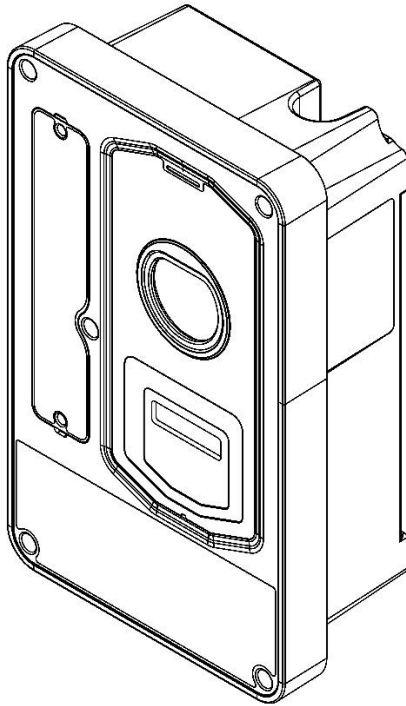

CONTENT

1	SAFETY INSTRUCTIONS	2
2	LEGAL NOTE.....	2
3	DESCRIPTION OF OPERATION	2
3.1	Functional description	2
3.2	Parts of interest to the installer and the user.	3
4	INSTALATION.....	3
4.1	Wallare mesh infrastructure	3
4.2	Initial configuration of the charging points	4
4.3	Initial configuration of the wallare mesh	6
5	CONFIGURATION	8
5.1	Configuration of charging points	8
5.2	Charging point configuration parameters	9
5.3	Wallare mesh configuration	10
5.4	Wallare mesh configuration settings	13
6	MAINTENANCE.....	15
7	WARRANTY AND TECHNICAL SERVICE.....	15

1 SAFETY INSTRUCTIONS

This manual contains important instructions to ensure the safety of people and the integrity of goods near or connected to the charging facility. Before starting the installation, please read this manual carefully and in its entirety and make sure you have understood it perfectly. If in doubt, consult the teknoCEA technical service.



The installation of this product must be carried out in accordance with the regulations applicable to the country of installation and must be carried out by qualified personnel who have the necessary certifications and qualifications to carry out work with low voltage electrical installations.

Failure to comply with the safety instructions and warnings presented in this manual, the applicable regulations or the non-qualification of the personnel involved in the installation of the product may result in any of the following effects:

- i. Electric shocks on people that can become fatal.
- ii. Material damage of all kinds, both to the device itself and to the rest of the elements of the installation, including the vehicle.
- iii. Fires with material damage to elements near the facility.

TeknoCEA is not responsible for any of the damages mentioned above.

Security warnings will be marked as follows:

	CAUTION	It indicates actions to be taken to prevent damage to any element of the installation or near the installation or damage to people.
	DANGER	It indicates sources of danger of damage to any element of the installation or near the installation or damage to people.

2 LEGAL NOTE

This installation manual has been prepared in order to provide detailed and accurate information on the installation, use and maintenance of the product. Although every effort has been made to ensure the accuracy of the information contained in this document, the manufacturer assumes no responsibility for errors, omissions, or damages arising from the use of this manual.

The manufacturer reserves the right to make modifications to the technical specifications of the product and the associated documentation at any time and without prior notice. Changes made to the product do not imply any responsibility on the part of the manufacturer towards previous versions of the manual or other related documents.

It is the user's responsibility to follow the installation and operating instructions in a safe manner and in accordance with current regulations. The user must ensure that the installation is carried out by qualified professionals and that it complies with all applicable local laws and regulations.

The manufacturer shall not be liable for damage to property or persons resulting from incorrect installation, improper use or unauthorized dismantling of the product.

3 DESCRIPTION OF OPERATION

3.1 Functional description

The device has all the necessary electronics to be able to control charging (communications with the vehicle), to be able to read RFID cards and to be able to authorize charges and bill energy through a back end equipped with the OCPP communications protocol.

For OCPP communications a gateway is required, the TeknoCEA wallare mesh model, connected to a private ethernet network of the company operating the charging point. The set of installed devices (charging points and

gateway) will form a wireless mesh network that will communicate all points with the gateway. Using the ethernet connection, the gateway will communicate with the back end using the OCPP protocol.

This manual explains step by step how to make the initial configuration of both the wallare mesh device and the charging point, as well as the configuration of other parameters that can be modified at any time.

3.2 Parts of interest to the installer and the user.

To use the charging point, the parts indicated in the Fig. 1 must be identified.

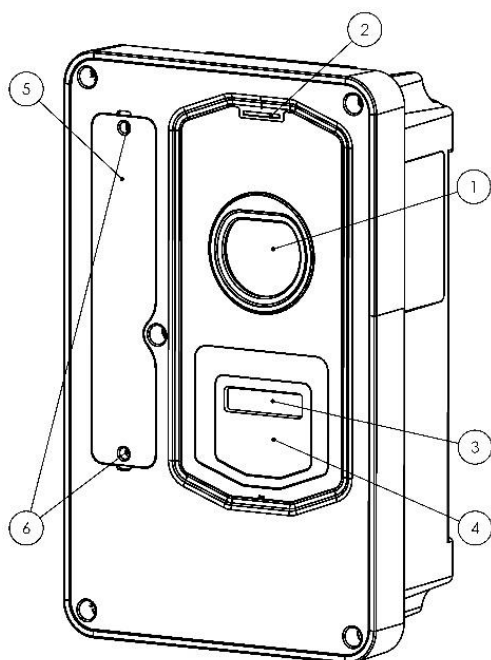

Numbering	Description
①	Plug according to IEC 62196 type 2 standard. This is the point where the charging cable is plugged in.
②	Indicator light. Indicates the status of the charger by colour and the continuity or flashing of light.
③	16 x 2 alphanumeric display. It indicates situations of interest to the user and actions to be carried out in the top line. The bottom line indicates the meter reading in kWh (totalizer).
④	RFID reader area. To identify the user, the tag must be brought close to this point.
⑤	Lid. It is used to access the protections and to be able to cut off the supply to the charging point.
⑥	Screws fastening the lid.

Fig. 1. Points of interest for the installer and user.

4 INSTALATION

	CAUTION	All the work described in this section must be carried out by specialized personnel who have received compulsory training in occupational risks and electrical installations in accordance with the type of operations described therein.
--	----------------	---

	CAUTION	Make sure that during the handling of the base and the connection of the connection, it does not have any active or residual voltage
--	----------------	--

	DANGER	The work described in this manual involves an electrical hazard that may result in serious injury or death to the personnel involved.
--	---------------	---

4.1 Wallare mesh infrastructure

As explained above, the wallare mesh system works with wireless communication and restrictions must be considered regarding the distance between the charging points and the wallare mesh. On the one hand, the maximum distance between two consecutive points must be 8 meters, and the maximum distance between the wallare mesh and the nearest charging point must also be 8 meters. A wallare mesh will be able to control a maximum of 25 charging points. The phase of the electricity grid to which each charging point is connected for smart charging (currently in the testing phase) must also be taken into account. The following image shows an example of a possible real layout in a parking area.

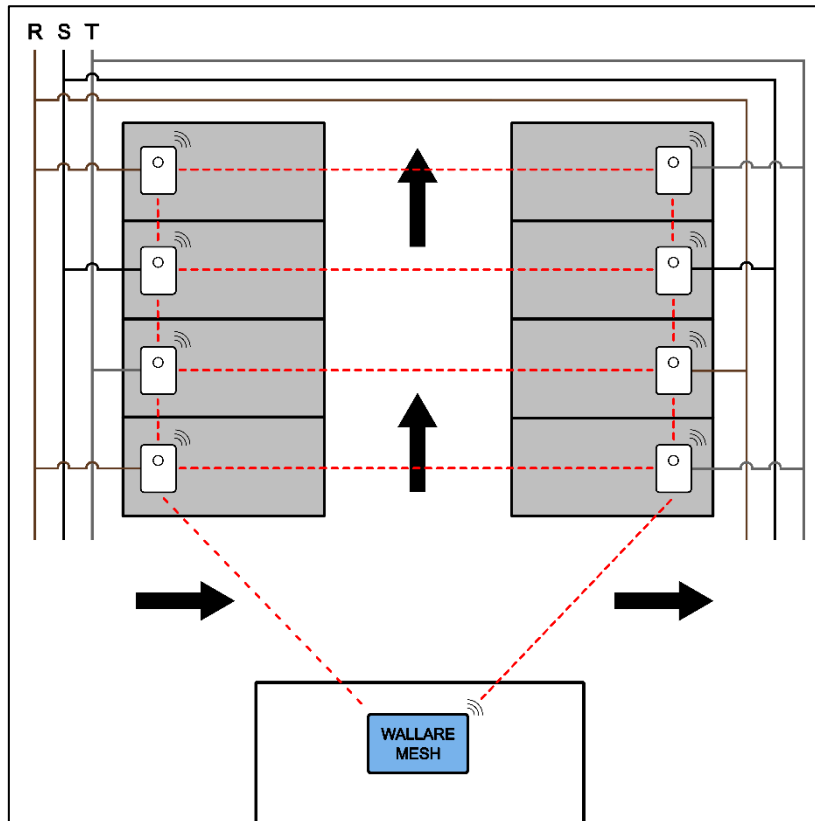

Fig. 2. Example of a real layout in a car park.

On the other hand, for the points to have communication with the wallare mesh gateway and with the backend, an initial configuration is necessary, both in the charging points and in the wallare *mesh*.

4.2 Initial configuration of the charging points

Before configuring the charging point, it will also be necessary to calibrate the plug gate. To do this, remove the lid, lower the protection and disassemble the cover. Then modify the position of the *jumper* to make a bridge between the *RST* and *COM* pins. Reassemble the cover and arm the protection to feed and wait for the door to go up and down (it may take about 10 seconds). Once done, disassemble the cover again and put the *jumper* making a bridge between *KEEP* and *COM*, reassemble the cover, assemble the protection and assemble the lid. In section 5.1 you can see a figure of the location of the *jumper*.

The configuration of the charging point serves to prepare it to connect with the wallare mesh walkway and be able to exploit the infrastructure. To configure the charging point, it has a Wi-Fi access point with a web server that can be accessed with a web browser. The access point will be available only for the first 3 minutes after connecting the main power. It is then turned off so as not to expose the device to configuration changes. The system does not require the installation of any software, beyond a web browser.

At the charging point you must essentially configure three parameters: connector number, *General UUID* and phase. The connector number is used to identify each point within the OCPP network of the wallare mesh. It should be noted that the plug number that is assigned to each point must be sequential, and no number can be skipped. For example, if the total number of points to be installed is 20, they must be numbered from 1 to 20. The *General UUID* must be the same as the one entered in the wallare mesh configuration. And the phase is the phase in which the charging point is plugged into the installation's electrical grid. Below are the steps to follow to make this configuration.

Access

1. Disassemble the lid
2. Turn off and on the protection (to cause a reboot)
3. With a PC or mobile device, connect to the *Wi-Fi access point* with SSID *PDR_AP*
4. Open a web browser and connect to the following address: 192.168.4.1
5. Enter the password. The default password is password1234

Remember that once you have restarted the charging point you have 3 minutes to connect to the server.

Note: disable mobile data before connecting to the web server.

Change of password

The first time you access the charging point, the system asks you to change your password. To prevent malicious attacks on the installation, keep the new password secret.

Main Settings Page

On the configuration page, the following parameters must be configured in the 'UUID configuration' section:

- *General UUID:* is a network code of 28 hexadecimal characters that must be common in all charging points connected to the same wallare mesh. To prevent malicious attacks on your installation, keep this code secret.
- *Connector number:* connector number inside the charging station.

In the case of using Smart Charging, in the 'Smart Charging Configuration' section, you must select the phase to

which the charging point that is being configured is plugged in.

Once the data has been modified, you must click on the "send data" button located at the bottom of the page, the web server will confirm the sending.

4.3 Initial configuration of the wallare mesh

To configure the wallare mesh, a computer or mobile phone with a browser will be required and the wallare mesh must be connected to the private ethernet network of the company operating the charging point. The wallare mesh works with *Power over Ethernet* (PoE), it means that is powered by the ethernet port, so it will have to be connected to an ethernet port with PoE. Once the wallare mesh is powered and connected to the network, it is necessary to open a web browser and enter the IP address assigned to the wallare mesh in the search engine to enter the web server for configuration.

When entering it will ask for a password, if it is the first time it is used, this is by default *password1234* and when entering it, it will force you to change it. For security, keep the new password secret.

Once inside the web server, you can change parameters of the wallare mesh network, OCPP parameters and parameters of the charging points (in section 5.4 all the parameters that can be configured in the wallare mesh are explained in more detail). To continue with the installation 2 parameters must be configured: the number of charging points and the *General UUID*.

The number of charging points is the number of points that will be connected to the wallare *mesh* that is being configured. This parameter is located in section 1 of the web server configuration page. The *General UUID* is an identifier of the network where all the points that have this key can be connected to the wallare mesh, so all the charging points that want to connect with the wallare mesh that is being configured must have this same *UUID* (the key must be made up of 28 hexadecimal characters). If more than one wallare mesh is being used, they must have a *different General UUID*. Here are the steps to perform this setup:

Access

1. With a PC or mobile device (being connected to the same network as the wallare mesh) open a web browser and connect to the IP address assigned to the wallare mesh.
2. Enter the password. The default password is *password1234*

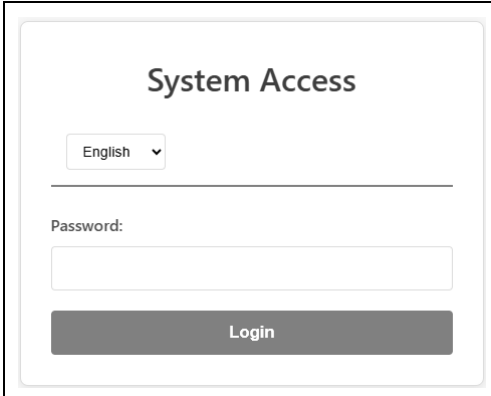

Change of password The first time you access the wallare mesh, the system asks you to *change* the password. In order to prevent malicious attacks on the installation, keep the new password secret.

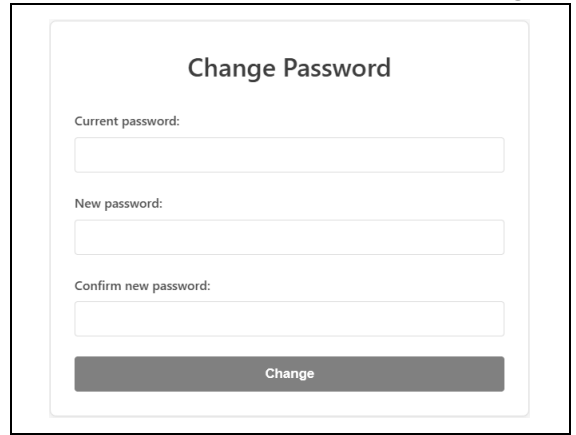

The screenshot shows a web form titled "Change Password". It contains three input fields: "Current password:", "New password:", and "Confirm new password:". Below these fields is a dark grey button labeled "Change".

Configuration page On the configuration page, go to section 1 (General Configuration) to configure the number of charging points (NumEvse) and the *General UUID* (this must be made up of 28 hexadecimal characters). In order to prevent malicious attacks on the installation, keep this key secret.

Also, to be able to connect to the backend of the infrastructure you will have to add the URL of the backend and the *chargebox id* that are in section 2 (Main parameters of OCPP).

Press the 'Send Data' button at the bottom of the page to save the settings.



The screenshot shows a configuration page with two sections. Section 1, "General Configuration", has two fields: "NumEvse (1-25)" with the value "2" and "General UUID" with the value "4554aaaaaaaaaaaaaaaaaaaaaaaa". Section 2, "Main OCPP parameters", has two fields: "URLBackend" with the value "ws://192.168.1.104:8080/steve/websocket/CentralSystemService" and "ChargeBoxID" with the value "chargebox_teknocea".

Once the wallare mesh and charging points are configured, wait for the charging points LED to be solid green before you can start charging.

5 CONFIGURATION

This section presents the complete operation of the web server for the configuration of both the charging points and the wallare mesh, as well as all the parameters that can be configured.

5.1 Configuration of charging points

Access

1. Disassemble the lid.
2. Turn off and on the protection (to cause a reboot).
3. With a PC or mobile device, connect to the Wi-Fi access point with SSID *PDR_AP*.
4. Open a web browser and connect to the following address: 192.168.4.1.
5. Enter the password. The default password is password1234.

Remember that once you have restarted the charging point you have 3 minutes to connect to the server.

Note: disable mobile data before connecting to the web server.

The screenshot shows a web interface titled "System Login". At the top, there is a language dropdown menu currently set to "English". Below this is a horizontal line. Underneath the line, the text "Password:" is followed by a rectangular input field. At the bottom of the form is a dark grey button with the word "Enter" in white text.

Configuration page

On the configuration page, you can modify the parameters related to the operation of the charging point and they are divided into the following sections:

- Section 1: UUID Settings.
- Section 2: EVSE Location.
- Section 3: Display settings.
- Section 4: Shutter Settings.
- Section 5: Setting the current limit and Smart Charging (in testing).

The description of each section can be found in section 5.2.

At the top of the page there is a language selector where you can choose between Catalan, Spanish and English.

At the bottom of this page, you will also find two buttons:

- Send data: Save your configuration data.
- Change password: Change the password of the web server.

Once the data has been modified, click on the "send data" button and the web server will confirm the sending.

The screenshot displays the "EVSE Configuration" page. At the top, there is a language dropdown menu set to "English". The page is divided into several sections, each with a title and a form field:

- UUID Configuration:** General UUID: 4554AAAAAAAAAAAAAAAAAAAA, Connector number: 0001
- EVSE Location:** EVSE Address: Carrer de Roca i Umbert, 16, 08907 L
- Display Configuration:** Display Language: Català
- Shutter Configuration:** Operation Mode: Only Turning
- Current limit and Smart Charging Configuration:** Smart Charging: Disabled, Current Limit (A): 32

Change of password

To change your password, go to the bottom of the page and click on the 'Change password' button. In order to prevent malicious attacks on the installation, keep the new password secret.

Password reset

If you have forgotten the modified password, you can return to the default one with the following operations:

1. Remove the lid, turn off the protection and remove the cover.
2. Modify the position of the *jumper* (see figure) to bridge the *RST* and *COM* pins.
3. Assemble the cover, turn on the protection to feed and wait 10 seconds.
4. Turn off the protection and disassemble the cover.
5. Put the *jumper* back in by bridging *KEEP* and *COM*.
6. Assemble the cover, turn on the protection and assemble the lid.

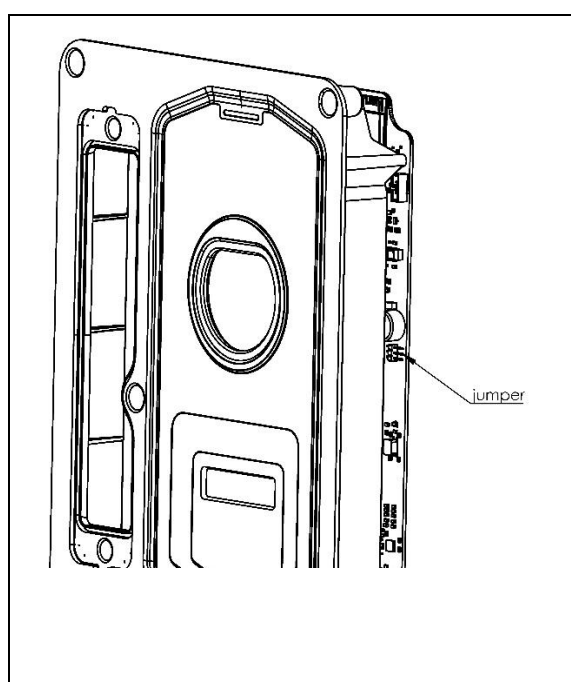
**5.2 Charging point configuration parameters**

Section	Parameter	Description
Section 1: UUID Configuration	General UUID	It is a network code of 28 hexadecimal characters that must be common in all chargers connected to the same wallare mesh. In order to prevent malicious attacks on your installation, keep this code secret.
	Connector number	Connector number within the OCPP network of the wallare mesh.
Section 2: EVSE Localization	EVSE Address	Physical address of the charging point.
Section 3: Display settings	Display Language	The language in which the text will be displayed on the screen.

Section 4: Shutter Settings	Operation Mode	<p>Operation of the plug gate:</p> <ul style="list-style-type: none"> • Twist Only: Opens if the charging cable is twisted on the gate. • Authorization only: Opens if charging is authorized. • Turning + authorization: opens if the charging cable is turned or if charging is authorized.
Section 5: Setting up Smart Charging	Smart Charging	<p>Disabled: Disables smart charging functionality.</p> <p>A: The charging point is plugged into phase R of the electricity grid.</p> <p>S: the charging point is plugged into phase S of the electricity grid.</p> <p>T: the charging point is plugged into the T phase of the electricity grid.</p>
	Current limit	<p>Maximum current that the charging point can supply.</p> <p>NOTE: This value will only be taken into account if smart charging is disabled. In the event that the limit configured in the wallare mesh and in the charging point is different, priority will be given to the most restrictive one.</p>

5.3 Wallare mesh configuration

Access

1. With a PC or mobile device, open a web browser and connect to the IP address assigned to the wallare mesh.
2. Enter the password. The default password is password1234

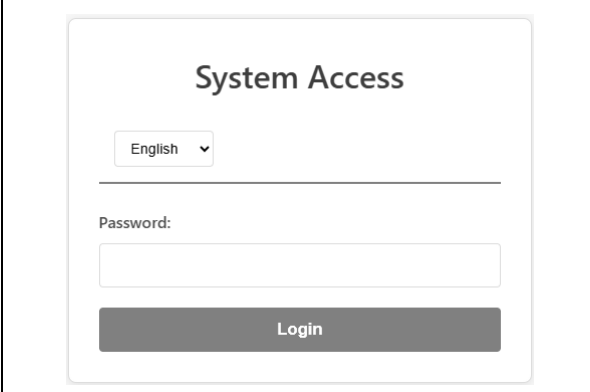

Change of password

To change your password, go to the bottom of the page and click on the 'Change password' button. In order to prevent malicious attacks on the installation, keep the new password secret.

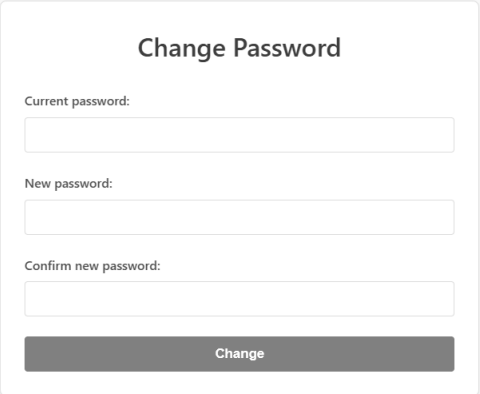

The image shows a 'Change Password' form. It has a title 'Change Password' at the top. Below the title are three input fields: 'Current password:', 'New password:', and 'Confirm new password:'. Each field is a simple rectangular box. At the bottom of the form is a dark grey button with the text 'Change' in white.

Configuration page

On the configuration page, you will find the parameters that are part of OCPP and the network of charging points divided into the following sections:

- Section 1: Network Configuration
- Section 2: Main Parameters of OCPP
- Section 3: Local List
- Section 4: Measurement
- Section 5: Transactions
- Section 6: Smart Charging (in testing) and current limit

The description of each section can be found in section 5.4

At the top of the page there is a web server language selector where you can choose between Catalan, Spanish and English.

At the bottom of this page, you will also find two buttons:

- Send data: Save your configuration data.
- Change password: Change the password of the web server.

Section 1: General Configuration

NumEvse (1-25):

General UUID:

Section 2: Main OCPP parameters

URLBackend:

ChargeBoxID:

ChargerPointModel:
wallare_park

ChargerPointVendor:
teknoCEA

Heartbeat Interval (60 - 86400):

WebSocket Ping Interval (10 - 30):

Section 3: Local List

Authorization Cache Enabled

Local Pre Authorize

Local Auth List Enabled

Local Auth List MaxLength
48

Send Local List Max Length
48

Section 4: Metering

Energy_Active_Import_Register

Power_Active_Import

Current_Import

Meter Value Sample Interval (10 - 60):

Section 5: Transactions

Authorize Remote Tx Requests

Stop Transaction On EV Side Disconnect

Stop Transaction On Invalid Id

Connection Time Out (50 - 300):

Transaction Message Attempts (3 - 5):

Transaction Message Retry Interval (30 - 60):

Secció 6: Smart Charging and current limit

Smart Charging

Current Limit (A)

5.4 Wallare mesh configuration settings

On this page you can change the network parameters of the wallare mesh and OCPP parameters.

Section	Parameter	Description
Section 1: General Settings	Num Evse (1-25)	Total number of charging points within the wallare mesh network. Number between 1 and 25.
	General UUID	Key to the network of the wallare mesh. This must be the same at all charging points. 28 hexadecimal characters.
Section 2: Main Parameters of OCPP	Backend URL	URL of the central system.
	ChargeBoxID	Identifier of the wallare mesh.
	Heartbeat Interval	Time interval between Heartbeats (in seconds).
	WebSocket Ping Interval	Time interval between pings (in seconds).
Section 3: Local List	Authorization Cache Enabled	<p>Enabled: A local list is maintained with all identifiers that have been submitted and authorized by the central system.</p> <p>Disabled: authorization from the central system is required each time an identifier is presented.</p>
	Local Pre Authorize	<p>Enabled: Searches if the submitted identifier has already been previously authorized without waiting for authorization from the central system.</p> <p>Disabled: Requests authorization from the central system of the ID presented to initiate a charge.</p>
	Local Auth List Enabled	<p>Enabled: Enabled local authorization list.</p> <p>Disabled: Local authorization list disabled.</p>
	Local Auth List Max Length	<p>Maximum size of the local authorization list.</p> <p>NOTE: <i>This parameter cannot be modified, it is for informational purposes.</i></p>
	Send Local List Max Length	<p>The maximum number of identifiers that can be sent in a central system request.</p> <p>NOTE: <i>This parameter cannot be modified, it is for informational purposes.</i></p>
Section 4: Measurement	Energy Active Import Register	Ability: Includes the active energy imported into the MeterValue.

		Disabled: Does not include active energy imported into the MeterValue.
	Power Active Import	Ability: Includes the active power imported into the MeterValue. Disabled: Does not include the active power imported into the MeterValue.
	Current Import	Ability: Includes the imported current in the MeterValue. Disabled: Does not include the imported stream in the MeterValue.
	Meter Value Sample Interval	The time interval between each MeterValue when a charge is in progress (in seconds).
Section 5: Transactions	Authorize Remote Tx Requests	Enabled: Requests authorization when the central system sends a remote start. Disabled: Starts charging when the central system sends a remote start.
	Stop Transaction On EV Side Disconnect	Enabled: The transaction is stopped if the charging cable is disconnected. Disabled: The transaction continues even if the charging cable is disconnected from charging point.
	Stop Transaction On Invalid Id	Enabled: The transaction is stopped if a response is received from the central system informing that the user is blocked, invalidated, or expired. Disabled: The transaction continues even if the central system rejects the user.
	Connection Time Out	Maximum time to connect the charging cable since the transaction was authorized (in seconds).
	Transaction Message Attempts	Number of times the wallare mesh sends a request to the mainframe.
	Transaction Message Retry Interval	Time interval between request attempts to the central system (in seconds).

Section 6: Smart Charging	Smart Charging	<p>Enabled: Smart charging is activated.</p> <p>Disabled: Smart charging is deactivated.</p> <p>NOTE: <i>Smart charging is currently in the testing phase.</i></p>
	Current limit	<p>Maximum current that the charging points can supply</p> <p>NOTE: <i>This limitation applies to all charging points.</i></p>

6 MAINTENANCE

No maintenance operation is required, beyond checking the torque of the base connections (protection and meter).

	PRECAUTION	<ol style="list-style-type: none"> 1. All maintenance operations must be carried out by personnel with adequate training in electricity, electrical risk and in general, to carry out the operations described. 2. Make sure that the charger power is disconnected before performing maintenance operations. 3. If the cover is to be dismantled, remove the lid beforehand and turn off the protection.
---	------------	--

7 WARRANTY AND TECHNICAL SERVICE

This product is warranted against defects in workmanship and materials for a period of **three years** from the date of purchase. During this time, teknoCEA undertakes to repair or replace any defective unit at no cost to the owner, as it deems appropriate.

Repaired or replaced components will be covered for the same period as the original warranty and for at least a period of 6 months after repair.

This warranty does not cover damage caused by improper use, accidents, incorrect maintenance or normal wear and tear from use. Any unauthorized modification, integration or replacement of parts by the customer will be considered an inappropriate use of the product.

This limited warranty is supplemented by and does not replace or limit any statutory rights that may apply, except as permitted by applicable law.

In case of detecting any malfunction or defect, contact the technical service for instructions on how to proceed with its revision or repair.

You can contact the technical service by phone (+34) 93 802 78 16 or by email teknocea@teknocea.cat.