

# wallare park wallare park sk

Installation manual – English  
Rev. 1.1

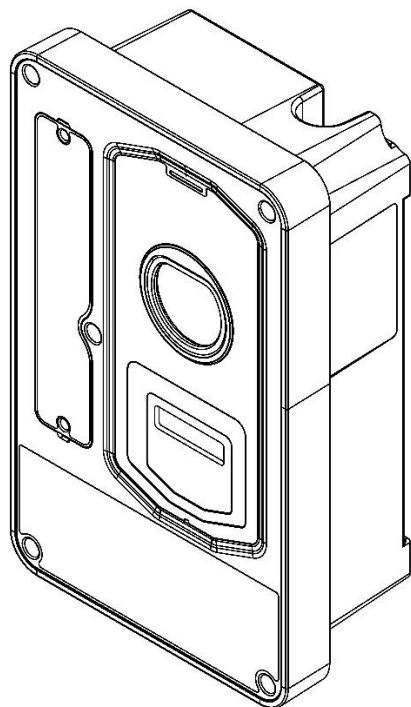

## CONTENT

|     |  |    |
|-----|--|----|
| 1   | SAFETY INSTRUCTIONS .....                                | 2  |
| 2   | LEGAL NOTE.....  | 2  |
| 3   | PRODUCT DESCRIPRION.....                                 | 2  |
| 3.1 | Functional description .....                             | 2  |
| 3.2 | Technical features .....                                 | 3  |
| 3.3 | Classification according to IEC 61851-1 .....            | 4  |
| 3.4 | Classification and ratings according to IEC 61439-7..... | 4  |
| 3.5 | Parts of interest to the installer and the user. ....    | 5  |
| 3.6 | Product reference .....                                  | 5  |
| 4   | INSTALATION.....   | 6  |
| 4.1 | Inspection and storage .....                             | 6  |
| 4.2 | Package contents.....                                    | 6  |
| 4.3 | Necessary tools .....                                    | 7  |
| 4.4 | Protections .....  | 7  |
| 4.5 | Drilling the wall and assembling the base.....           | 8  |
| 4.6 | Connection.....  | 9  |
| 4.7 | Closing.....   | 10 |
| 5   | VINYL WRAPPING.....                                      | 11 |
| 6   | CONFIGURATION .....                                      | 11 |
| 7   | MAINTENANCE.....   | 13 |
| 8   | WARRANTY AND TECHNICAL SERVICE.....                      | 13 |

## 1 SAFETY INSTRUCTIONS

This manual contains important instructions to ensure the safety of people and the integrity of goods near or connected to the charging facility. Before starting the installation, please read this manual carefully and in its entirety and make sure you have understood it perfectly. If in doubt, consult the teknoCEA technical service.



The installation of this product must be carried out in accordance with the regulations applicable to the country of installation and must be carried out by qualified personnel who have the necessary certifications and qualifications to carry out work with low voltage electrical installations.

Failure to comply with the safety instructions and warnings presented in this manual, the applicable regulations or the non-qualification of the personnel involved in the installation of the product may result in any of the following effects:

- Electric shocks on people that can become fatal.
- Material damage of all kinds, both to the device itself and to the rest of the elements of the installation, including the vehicle.
- Fires with material damage to elements near the facility.

TeknoCEA is not responsible for any of the damages mentioned above.

Security warnings will be marked as follows:

|   |         |   |
|---|---------|---|
|    | CAUTION | It indicates actions to be taken to prevent damage to any element of the installation or near the installation or damage to people. |
|  | DANGER  | It indicates sources of danger of damage to any element of the installation or near the installation or damage to people.           |

## 2 LEGAL NOTE

This installation manual has been prepared in order to provide detailed and accurate information on the installation, use and maintenance of the product. Although every effort has been made to ensure the accuracy of the information contained in this document, the manufacturer assumes no responsibility for errors, omissions, or damages arising from the use of this manual.

The manufacturer reserves the right to make modifications to the technical specifications of the product and the associated documentation at any time and without prior notice. Changes made to the product do not imply any responsibility on the part of the manufacturer towards previous versions of the manual or other related documents.

It is the user's responsibility to follow the installation and operating instructions in a safe manner and in accordance with current regulations. The user must ensure that the installation is carried out by qualified professionals and that it complies with all applicable local codes and regulations.

The manufacturer shall not be liable for damage to property or persons resulting from incorrect installation, improper use or unauthorized dismantling of the product.

## 3 PRODUCT DESCRIPTION

### 3.1 Functional description

The *wallare park* is a mode 3 electric vehicle charging point, i.e. alternating current, designed for charging in public spaces. From a single-phase power supply, it provides a plug according to IEC 62196, type 2, in order to connect a compatible charging hose, which connects the charging point to the vehicle. Additionally, the *sk* version has a Schuko-type socket.

The device has all the necessary electronics to be able to control charging (communications with the vehicle), to be able to read RFID cards and to be able to authorise recharges and bill energy through a *back end* equipped with the OCPP communications protocol.

For OCPP communications, it will be necessary to install a gateway, *teknoCEA's* wallare mesh model, connected to a private *ethernet* network of the company operating the charging point. The set of installed devices (charging points and gateway) will form a wireless mesh network that will communicate all points with the gateway. Using the *ethernet connection*, the gateway will communicate with the *back end* using the OCPP protocol.

### 3.2 Terms of use

This equipment is qualified as class A according to the IEC 61851-21-2 standard and is therefore intended for non-residential use. Due to higher electromagnetic emissions, its operation in residential locations is generally not permitted.

However, under controlled conditions, class A equipment may be used in residential environments. It should be noted that the emissions could cause interference with nearby sensitive equipment. In the event of interference, the distance between the charging point and the affected equipment should be increased and/or additional filtering or shielding measures should be implemented.

### 3.3 Technical features

The table below shows the characteristics of the *wallare park* and *wallare park sk models*.

| Model                                 | <i>wallare park</i>   | <i>wallare park sk</i>  |
|---------------------------------------|---|---|
| Charger type                          | IEC61861, AC, mode 3, indoor/outdoor installation   |   |
| Supply                                | Single-phase, L + N + PE  |   |
| Nominal voltage                       | 230 V   |   |
| Rated current                         | 32 A  | 16 A  |
| Rated power                           | 7,4 kW  |   |
| Connection to the vehicle:            | Socket according to IEC 62196 type 2 with motorized shutter and locking mechanism, with one-hand operation. | Socket according to IEC 62196 type 2 with motorized shutter and locking mechanism, with one-hand operation and Schuko |
| User Interface                        | RGB LED and 16 x 2 characters alphanumeric display  |   |
| Energy meter                          | MID Class B Certificate   |   |
| RFID Reader                           | ISO/IEC 14443 A/MIFARE  |   |
| Charge control                        | By pilot function according to IEC 61851  | By pilot function according to IEC 61851 in IEC 62196 type 2 plug. Non-existent in schuko                             |
| Protections                           | 6 mA DC residual current sensor, in compliance with IEC 62955   |   |
| Communications                        | OCPP 1.6 through the integration gateway  |   |
| Degree of protection of the enclosure | IP54  | IP44  |
| Mechanical Impact resistance          | IK10, except for the display and schuko area (IK08)   |   |
| External dimensions                   | 218 x 352 x 107 mm  |   |
| Operating temperature range           | -10..50 °C  |   |
| Operating humidity range              | 5..95% non condensation   |   |

|                       |   |
|-----------------------|---|
| Regulatory compliance | CE mark (directives BT 2014/35/EU, EMC 2014/30/EU, MID 2014/32/EU, RED 2014/53/EU)<br>Charging point: IEC 61851-1<br>Electromagnetic compatibility: IEC 61851-21-2<br>Socket IEC 62196-1 + IEC 62196-2<br>Energy meter: MID class B |
|-----------------------|---|

### 3.4 Classification according to IEC 61851-1

In accordance with the IEC 61851-1 standard and its definitions, the charging point is classified as follows:

System designed to be permanently connected to the single-phase electrical network, for indoor and outdoor installation in areas with restricted and unrestricted access; stationary, wall and surface installation; with class 1 electric shock protection; mode 3 charging with pilot function (according to Annex A) equipped with a protective earth cable on the connector; does not support the ventilation function (section 6.3.2.2).

### 3.5 Classification and ratings according to IEC 61439-7

The table below provides the classification data and information required in IEC 61439-7.

| Model   | <i>wallare park</i>  | <i>wallare park sk</i> |
|---|--|------------------------|
| Rated, utilization and isolation voltage [Un, Ue, Ui] | 240 V  |                        |
| Impulse voltage [Uimp]                                | 4 kV   |                        |
| Rated current [InA, Inc]                              | 32 A   | 16 A                   |
| Rated frequency [fn]                                  | 50 Hz  |                        |
| Peak rated current [Ipk]                              | 7,5 kA   |                        |
| Short period rated current [Icw]                      | 5 kA   |                        |
| Simultaneity factor                                   | 1  |                        |
| Degree of pollution                                   | III  |                        |
| Degree of protection and impact resistance            | IP54 / IK10  |                        |
| Grounding system                                      | TT   |                        |
| Type of installation                                  | Indoor and outdoor, fixed position and open to the general public. |                        |
| EMC Rating  | Class B  |                        |
| Protection against direct contacts                    | Plastic housing with IPXXD degree of protection.                   |                        |

### 3.6 Parts of interest to the installer and the user.

To use the charger, the parts indicated in Fig. 1 must be identified:

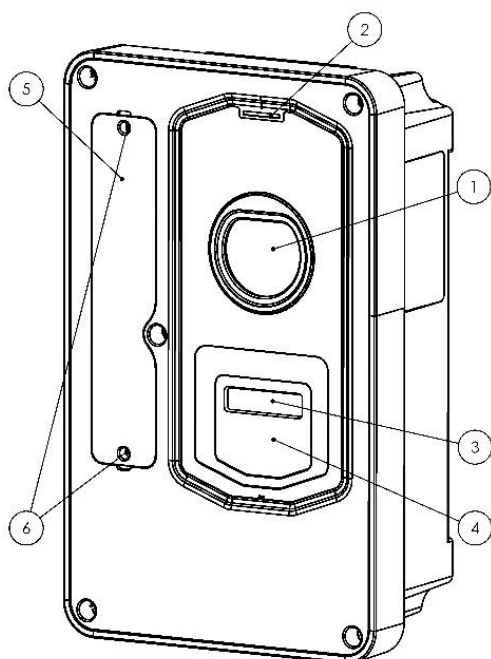

| Numbering | Description  |
|-----------|--|
| ①         | Socket according to IEC 62196 type 2 standard. This is the point where the charging cable is plugged in.   |
| ②         | Indicator light. Indicates the status of the charger by color and the continuity or flashing of light  |
| ③         | 16 x 2 alphanumeric display. It indicates situations of interest to the user and actions to be carried out in the top line. The bottom line indicates the meter reading in kWh (totalizer) |
| ④         | RFID reader area. To identify the user, the tag must be brought close to this point.   |
| ⑤         | Lid. It is used to access the protections and to be able to turn off the supply to the charging point.   |
| ⑥         | Screws fastening the lid.  |

Fig. 1. Points of interest for the installer and user.

### 3.7 Product reference

The serial number of the product is organized as follows:

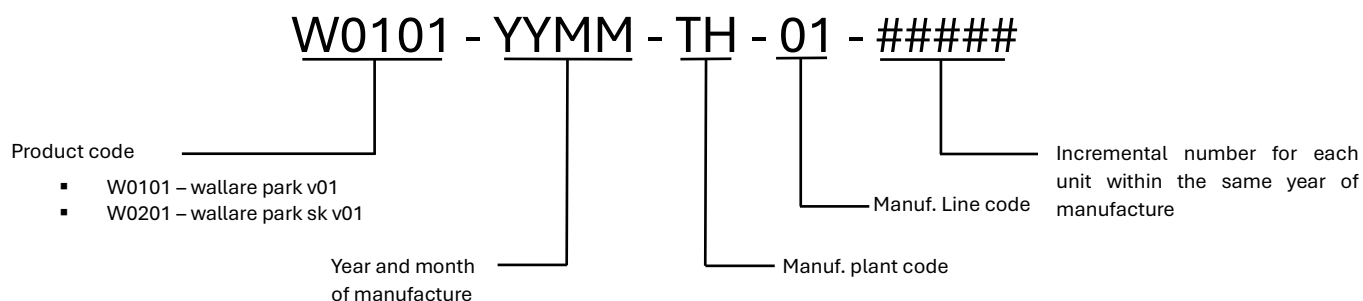

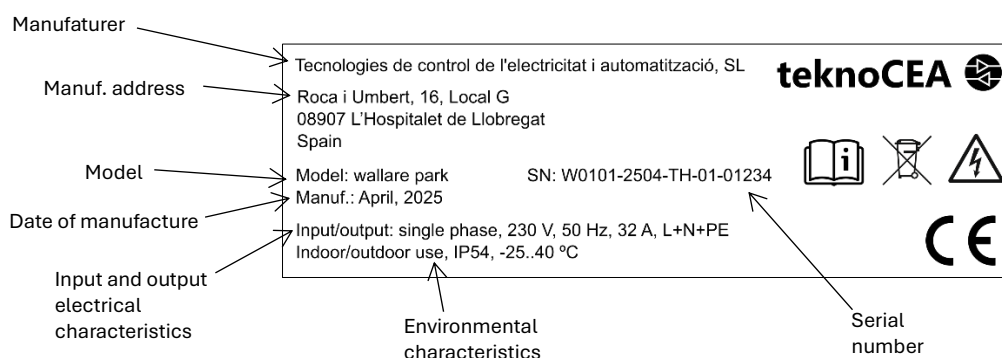

On the right side of the base is the product rating plate, with the following information:



## 4 INSTALATION

|   |         |   |
|---|---------|---|
|  | CAUTION | All the work described in this section must be carried out by specialised personnel who have received compulsory training in occupational risks and electrical installations in accordance with the type of operations described therein. |
|---|---------|---|

|   |         |   |
|---|---------|---|
|  | CAUTION | Make sure that during the handling of the base and the connection of the main supply, it does not have any active or residual voltage |
|---|---------|---|

|   |        |   |
|---|--------|---|
|  | DANGER | The work described in this manual involves an electrical shock risk that may result in serious injury or death to the personnel involved. |
|---|--------|---|







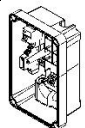
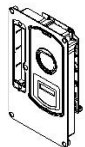

### 4.1 Inspection and storage

Before proceeding with installation, visually inspect for physical damage to any of the parts listed in Fig. 2 due to knocks during transport.

If you need to store the product, do so in a place with a temperature between 5 C and 40 °C, with a maximum relative humidity of 75% without condensation and in the original packaging.

### 4.2 Package contents

The parts included in the package are listed in the table below and can be identified in Fig. 2.

| Number (Fig. 2) | Draw  | Quantity | Name                | Functionality   |
|-----------------|---|----------|---------------------|---|
| ①               |  | x1       | Base                | It contains the main piece of fastening to the wall, the inlet for the power supply, the main protection, the meter, the cover connection plate and the necessary internal wiring.  |
| ②               |  | x1       | Cover               | It contains all the rest of the charger's electronics. It is a subassembly that is inserted into the base as a plug without the need to connect cables. It has an opening to activate the protections before it is removed. |
| ③               |  | x1       | Lid                 | It is used to cover the opening to activate the protections on the cover.   |
| ④               |  | x4       | Self-tapping screws | Screws $\varnothing = 4.5$ mm, L = 45 mm. They are used to mount the base onto the wall.  |
| ⑤               |  | x4       | Watertight washer   | They provide tightness to the charger in the clamping holes of the base once the self-tapping screws are glued.   |
| ⑥               |  | x4       | Wall anchor         | Wall anchors $\varnothing = 6$ mm, L = 30 mm. They are used to integrate the fastening screws into the wall.  |
| ⑦               |  | x5       | Safety screw        | M4 x 8 mm screws with T20 safety Torx drive. They are used to mount the cover onto the base.  |
| ⑧               |  | x2       | Lid screw           | M3 x 6 mm screws with <i>pozidriv drive</i> . They are used to mount the lid onto the cover.  |
| ⑨               |  | x1       | Cable gland         | It is used to provide tightness to the charger in the cable entry of the base. It consists of 3 parts: the gland, the gasket and the nut.   |

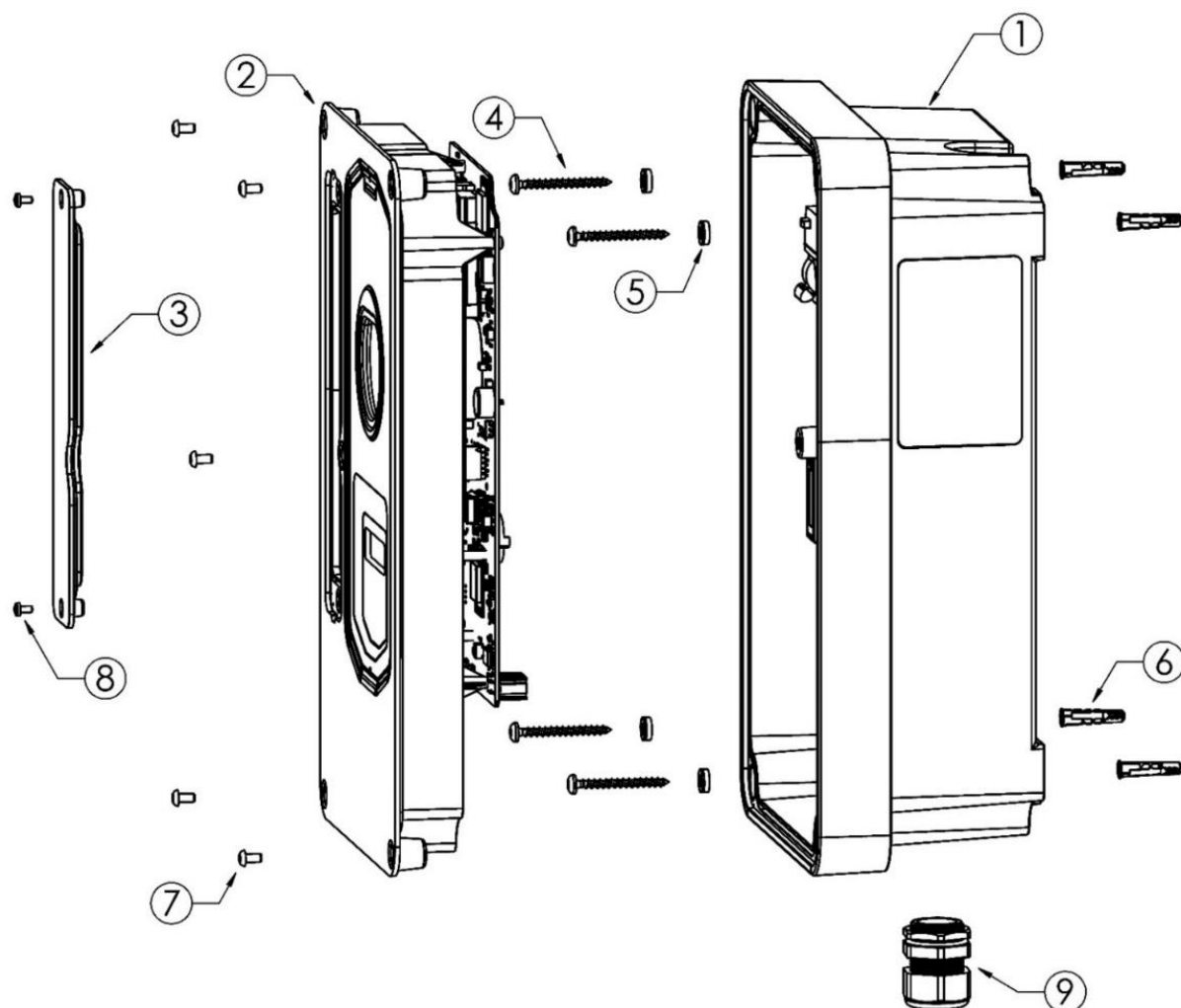

Fig. 2. Disassembly of components included in the packaging

### 4.3 Necessary tools

For the installation of the charger, the following tools will be required, not included in the packaging:

- T20 Torx screwdriver for security screws
- Small pozidriv screwdriver (for M3 x 6 screws on the lid)
- Large pozidriv screwdriver (for the screws on the mains protection)
- Medium flat screwdriver (protective earth terminal)
- Drill with hammer function.
- 6mm wall drill Bit
- Spirit level
- Tape measure
- Pencil
- Cutting pliers

### 4.4 Protections

The charger has a 40 A (*wallare park*) or 16 A (*wallare park sk*), C curve thermal magnetic protection plus a 30 mA type A residual current protection. It also has an 6 mA RDC residual current sensor for leak detection in 6 mA direct current in accordance with the IEC 62955 standard. With these systems, both the charger and the charging cable and the rest of the downstream parts are protected.

The power cable and in general any component connected upstream must be protected with additional elements according to the regulations or codes of each country. The damage caused by the non-protection of these components will not be the responsibility of teknoCEA in any case.

In general, the protections must meet the following requirements:

- Thermal magnetic protection: 40 A protection for the *wallare park* point and 16 A for the *wallare park sk* point, in accordance with IEC 60898-1, IEC 60947-2 or IEC 61009-1.
- Residual current protection: 30 mA type A protection, in accordance with 61008-1, IEC 61009-1, IEC 60947-2 or IEC 62423.
- Transient and/or permanent surge protection: in accordance with the local regulation or code of each state.

|   |         |  |
|---|---------|--|
|  | CAUTION | It is mandatory to install at least one thermal magnetic protection dedicated exclusively to the charging point. The protection included in the base complies with this requirement. Do not disassemble or manipulate this protection. |
|---|---------|--|

|   |         |   |
|---|---------|---|
|  | CAUTION | Additional mandatory requirements for low voltage protections may come from the local regulations or codes of each member state. Review them and follow all applicable regulations. |
|---|---------|---|

The rated current of the charger is 32 A for the *wallare park* version and 16 A for the *wallare park sk* version. To avoid interruptions in the supply of the protections, it is advisable to size the installation by 40 A and 20 A respectively. Install at least 10 and 6 mm<sup>2</sup> cross-sectional multi-stranded copper cable, respectively.

|   |         |   |
|---|---------|---|
|  | CAUTION | The requirements for the necessary cable sections are outlined in each state's local regulations or codes. Review them and follow all applicable regulations. |
|---|---------|---|

#### 4.5 Drilling the wall and assembling the base

|   |         |  |
|---|---------|--|
|  | CAUTION | <ol style="list-style-type: none"> <li>1. The charger must be installed in a stationary location and is designed to be installed on a vertical wall on surface.</li> <li>2. The charger must be installed on a surface that supports the weight of the charger and the insertion and removal forces of the connector.</li> <li>3. It is necessary to ensure that the charger is installed in an area that is sufficiently ventilated to prevent it from heating up.</li> <li>4. Do not install the charger near flammable substances, hot or cold air outlets, heat sources or flood zones.</li> </ol> |
|---|---------|--|

Install the charger on a completely flat, vertical surface.

The charger has a space at the back to accommodate the vertical ducting tube for the main power cables. This tube space is located in a vertical direction through the entire magazine and displaced 48 mm to the right of the vertical axis of symmetry (see Fig. 3) and allows a tube of up to 32 mm in outer diameter to be fitted. It is advisable to take this fact into account before installing the tube, as it conditions the position of the charging point.

In order to mount the charger onto the wall, use the base and level to mark the holes, which are located in the position of Fig. 3. The height of the lower limit of the charger with respect to the ground (h dimension) must be at least 900 mm. Verify compliance with this dimension before and after marking the holes.

Use the hammer drill and a 6 mm diameter wall drill bit to drill 4 holes in the marked position. The minimum depth of the holes must be 40 mm.

Insert the 4 anchors into the holes and attach the base onto the wall using the 4 self-tapping screws of 4.5 mm diameter and 45 mm long with the T20 torx screw driver using the 4 watertight washers included (see Fig. 2). The washers have a metal side and a rubber side. Position the metal part outwards, in contact with the screw heads.

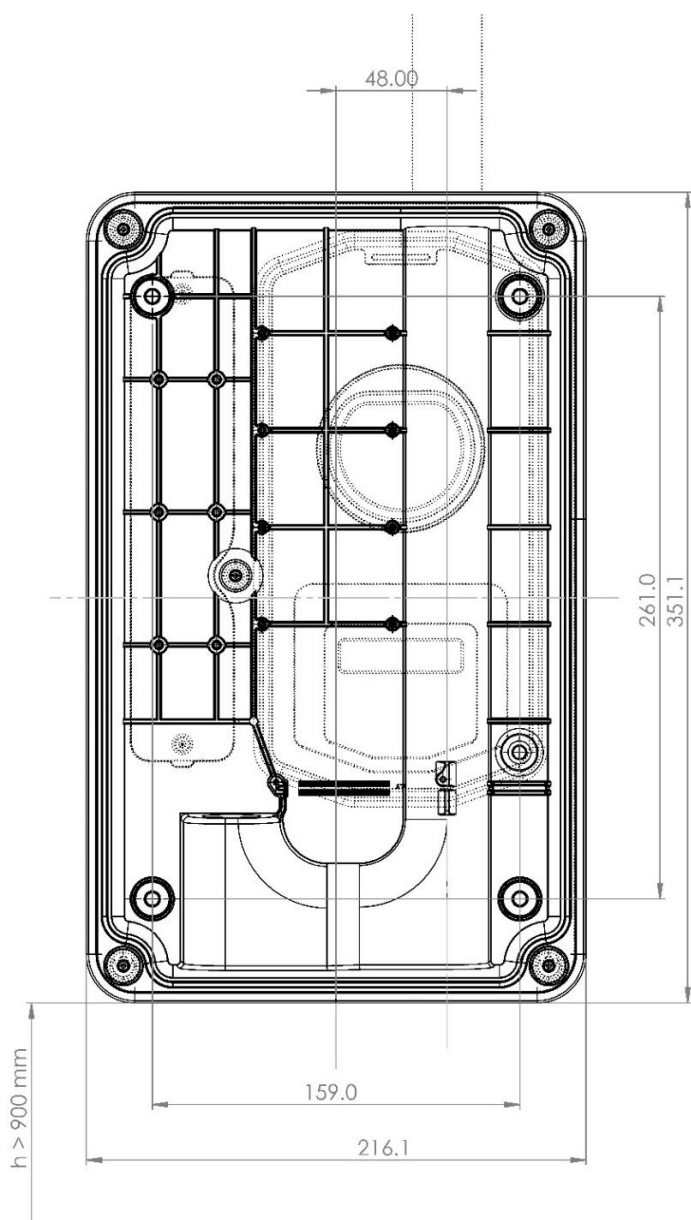



Fig. 3. Dimensions for the assembly of the base

|   |         |  |
|---|---------|--|
|  | CAUTION | The IP54 degree of protection will not be guaranteed if the watertight washers are not used or installed correctly. If in doubt, please contact the technical service. |
|---|---------|--|

#### 4.6 Connection

The charging point requires a single-phase connection with line, neutral and ground cables. For the supply connection of the device, it is necessary to use a single-phase 3-core cable (housed in a single outer cover) of the section specified in section 4.4.

|   |         |   |
|---|---------|---|
|  | CAUTION | The IP54 degree of protection will not be guaranteed if individual cables are used per line, neutral and ground, facilitating the entry of water and solid elements inside the charger. |
|---|---------|---|

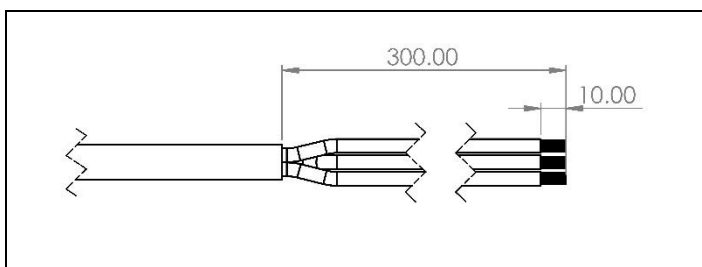

1. Remove the outer cover of the cable leaving a length of each of the 3 cables of 300 mm. Also remove 10 mm of cover from the end of each individual cable, leaving this length of bare copper for subsequent connection.

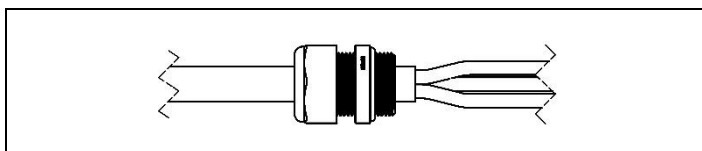

2. Separate the nut from the gland. Pass the cable through the cable gland and press the outer cover of the cable near the end of it.

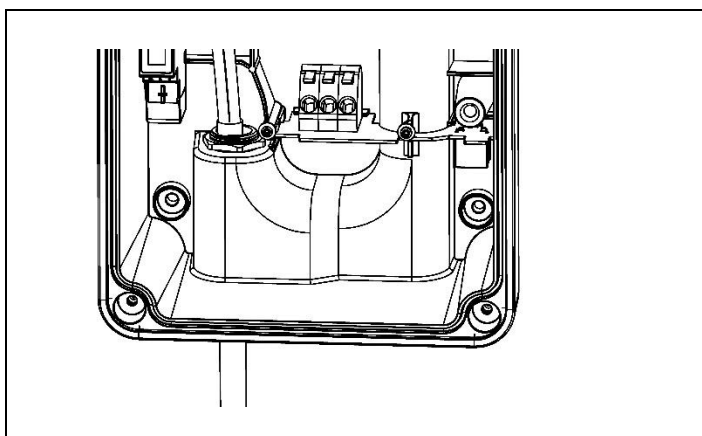

3. Insert the cable through the entry hole in the base. Subsequently, insert the nut of the gland into the cable and tighten the tow press to the base.

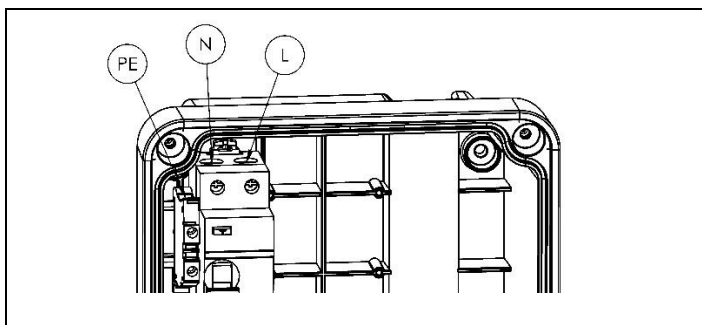

4. Connect line (L), neutral (N) and ground (PE) at the points shown in the figure (line and neutral are connected to the top of the main protection, while the ground is connected to a specific yellow/green DIN rail mounting terminal).

|  |                |  |
|--|----------------|--|
|  | <b>CAUTION</b> | Be sure to correctly identify the line (L) and the neutral (N) and to connect each of the wires to their position, according to step 4 of this section. Swapping out these connections may damage the vehicle's electronics. |
|--|----------------|--|

#### 4.7 Closing

Without supply voltage, insert the cover (without the lid) into the base and screw in the 5 M4 x 8 mm safety screws. With the cover mounted, turn on the main protection through the opening. Then insert the lid and mount it with the 2 M3 x 6 mm screws.

|  |                |   |
|--|----------------|---|
|  | <b>CAUTION</b> | Inserting or removing the cover with supply voltage may cause damage to the electronics of the charging point. Before removing the cover, make sure that the protection is lowered. Never turn on the main protection before putting the cover back on. |
|--|----------------|---|

|   |                      |   |
|---|----------------------|---|
|  | <p><b>DANGER</b></p> | <p>During assembly or maintenance periods when the base is installed with tension on the power line, ensure that the main protection turned off. Otherwise, there will be a high risk of direct contact that can result in serious injury or death to the personnel involved.</p> |
|---|----------------------|---|

**5 VINYL WRAPPING**

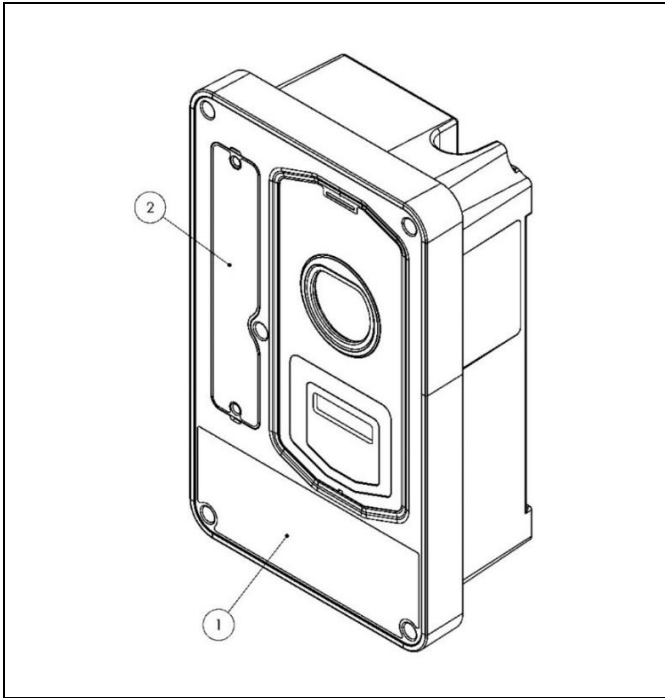

The charging point has surfaces designed to accommodate vinyl pieces that give information to the user in order to use the device, such as *APPs* to download, procedure for starting and ending the charging process, assistance telephone number, identifier of the charging point, corporate image of the infrastructure operator, etc.

In this manual, priority is given to wide flat areas and, specifically, two vinyl zones are identified, zone 1 and zone 2, as shown in the figure.

Vinyls are not included in the package. At the bottom, the relevant dimensions of the two areas are shown, in order to facilitate their design.

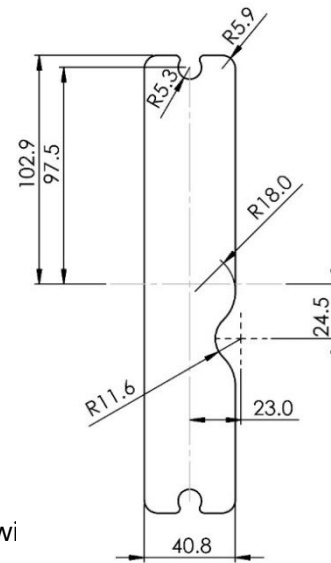
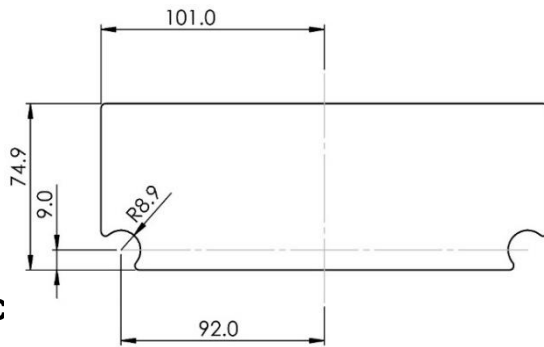

**6 C**

The configuration of the charging point serves to prepare it to connect with a web server. In order to configure the charging point with a web server, the *wifi* point will be available only for the first 3 minutes after connecting the main power. It is then turned off so as not to expose the device to configuration changes. The system does not require the installation of any software, beyond a web browser.

way and thus point with a

**Access**

1. Remove the lid
2. Turn off and on the main protection (to force a restart)
3. With a PC or mobile phone/tablet, connect to the wifi access point (SSID *PDR\_AP*)
4. Open the web server and connect to the IP address: 192.168.4.1
5. Type the password (By default is 12345678)

Remember that once you have restarted the charging point you have 3 minutes to connect to the server.

*Note: turn off mobile data before connecting to the web server.*

**Password change**

The first time you access the charging point configuration web server, the system asks you to change your password. In order to prevent malicious attacks on the installation, keep the new password secret.

**Configuration page**

On the configuration page, the following parameters must be configured in the 'UUID configuration' section:

- *General UUID*: is a network code of 28 hexadecimal characters that must be common in all charging points connected to the same wallare mesh. To prevent malicious attacks on your installation, keep this code secret.
- *Connector number*: connector number inside the charging station.

In the case of using Smart Charging, in the 'Smart Charging Configuration' section, you must select the phase to

which the charging point that is being configured is plugged in.

Once the data has been modified, you must click on the "send data" button located at the bottom of the page, the web server will confirm the sending.



### Password reset

If you have forgotten the modified password, you can return to the default one with the following operations:

1. Disassemble the lid, turn off the main protection, and disassemble the cover.
2. Modify the position of the *jumper* (see figure) to bridge the *RST* and *COM* pins.
3. Assemble the cover, turn on the protection to supply and wait 10 seconds.
4. Turn off the main protection and disassemble the cover.
5. Put the *jumper* back in by bridging *KEEP* and *COM*.
6. Assemble the cover, turn on the main protection and assemble the lid.

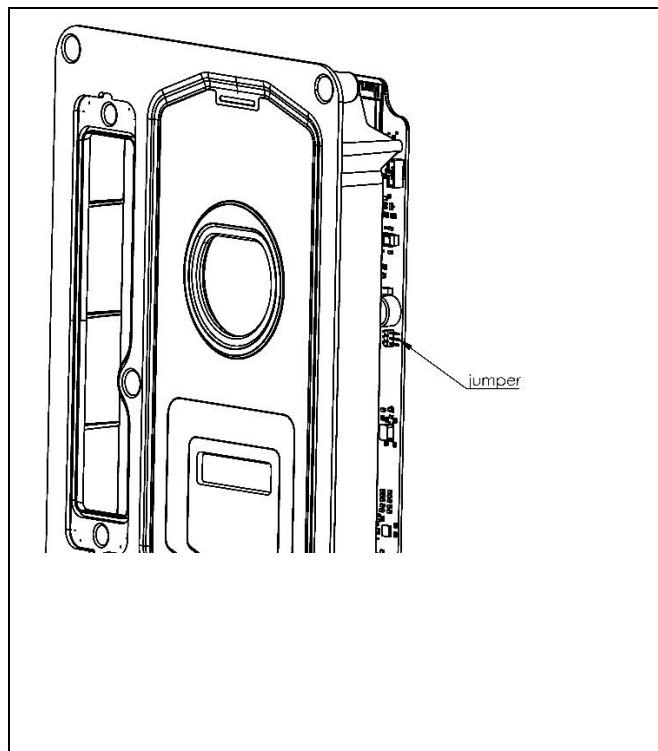

## 7 MAINTENANCE

No maintenance operation is required, beyond checking the torque of the base connections (protection and meter).

|   |         |   |
|---|---------|---|
|  | CAUTION | <ol style="list-style-type: none"> <li>1. All maintenance operations must be carried out by personnel with adequate training in electricity, electrical risk and in general, to carry out the operations described.</li> <li>2. Make sure that the charger power is disconnected before performing maintenance operations.</li> <li>3. If the cover is to be disassembled, remove the cover beforehand and turn of the protection.</li> </ol> |
|---|---------|---|

## 8 WARRANTY AND TECHNICAL SERVICE

This product is warranted against defects in workmanship and materials for a period of **three years** from the date of purchase. During this time, teknoCEA undertakes to repair or replace any defective unit at no cost to the owner, as it deems appropriate.

Repaired or replaced components will be covered for the same period as the original warranty and for at least a period of 6 months after repair.

This warranty does not cover damage caused by improper use, accidents, incorrect maintenance or normal wear and tear from use. Any unauthorized modification, integration or replacement of parts by the customer will be considered an inappropriate use of the product.

This limited warranty is supplemented by and does not replace or limit any statutory rights that may apply, except as permitted by applicable law.

In case of detecting any malfunction or defect, contact the technical service for instructions on how to proceed with its revision or repair.

You can contact the technical service by phone (+34) 93 802 78 16 or by email [teknocea@teknocea.cat](mailto:teknocea@teknocea.cat).